



INSTALLATION INSTRUCTIONS

Description	Page
Equipment required	1
Components	2
Step 1: Preparing the pipes	3
Step 2: Lubrication of the gasket	3
Step 3: Installing the coupling	
Step 3a: Aligning the pipes	3
Step 3b: Placing coupling on pipe	4
Step 3c: Adjusting setting gap	4
Step 3d: Slide coupling up to mark	4
Step 4: Tightening fasteners	5
Step 5: Testing	5
Operation and Maintenance	6
Storage	6
Troubleshooting	6

TORQUE WRENCH



SPANNER



RATCHET



LONG SOCKET



SOAPY WATER



MINERAL OIL



Couplings typically consist of three components and are typically pre-assembled. These components are :

- a) Two (2) end rings
- b) One (1) centre sleeve
- c) Two (2) rubber gaskets
- d) Bolts, nuts and washers

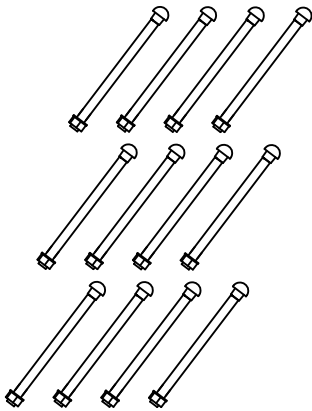

Bolts, nuts and washers
(Quantities dependent on model coupling)

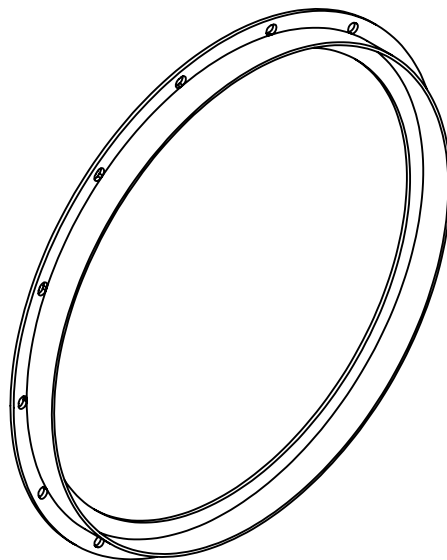

Two (2) End Rings

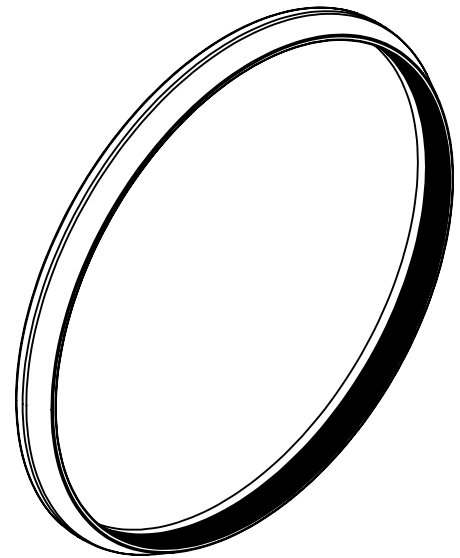

Two (2) Rubber Gaskets

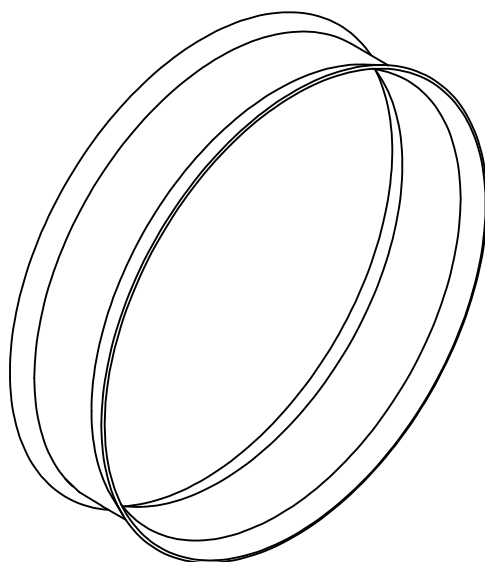

One (1) Centre Sleeve

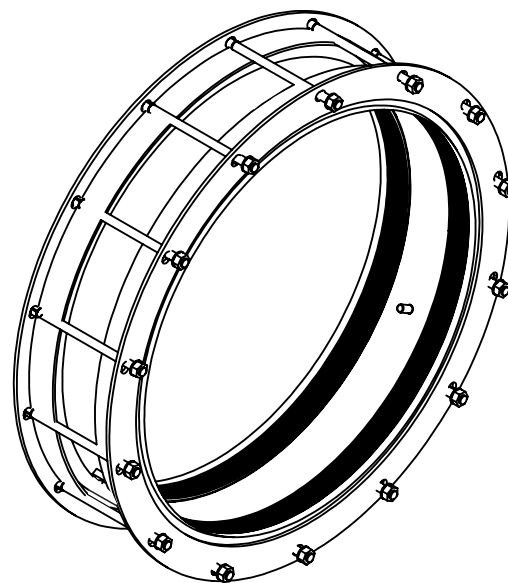

Assembled Coupling with bolts

PIPEJOINT COUPLINGS ARE PRE-ASSEMBLED DO NOT DISASSEMBLE

STEP 1: PREPARING THE PIPES

Examine the pipe ends ensuring they are round, smooth, free from bulges, dents, score marks, scale, rust or loose debris and within the correct pipe diameter range provided for the coupling. Weld beads must be ground flush, maintaining correct surface profile.

STEP 2: LUBRICATION OF THE GASKET

Lubrication of the gasket is very important. The rubber seal must be sufficiently lubricated where it comes into contact with the coupling centre barrel. Apply a suitable lubrication such as soapy water to the gaskets to ensure adequate lubrication. DO NOT use any mineral based oils as it will degrade the rubber used in the gasket.

STEP 3: INSTALLING THE COUPLING

a) Align pipes to be laid with pipe already in position, taking care that pipe ends are concentric, adjusting support or trench bed as necessary. Make a mark equal to half the overall assembled width of the coupling from the end of the installed pipe as well as the next pipe to be installed.

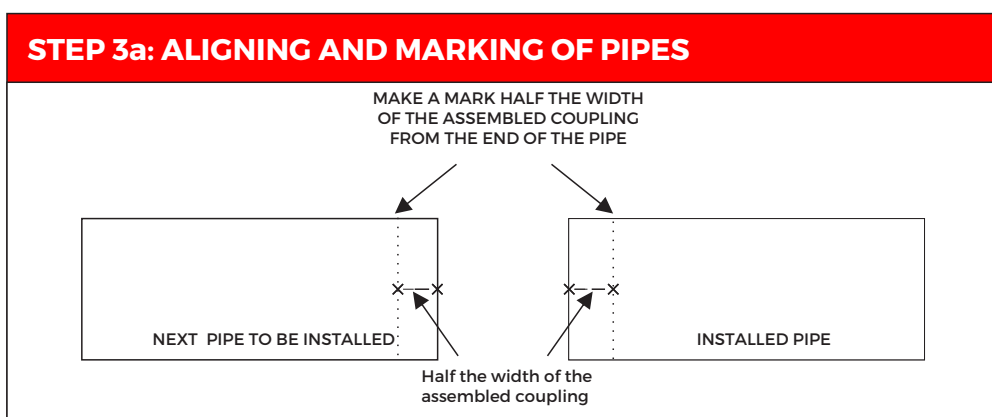

b) Place the whole coupling on one end of the installed pipe.

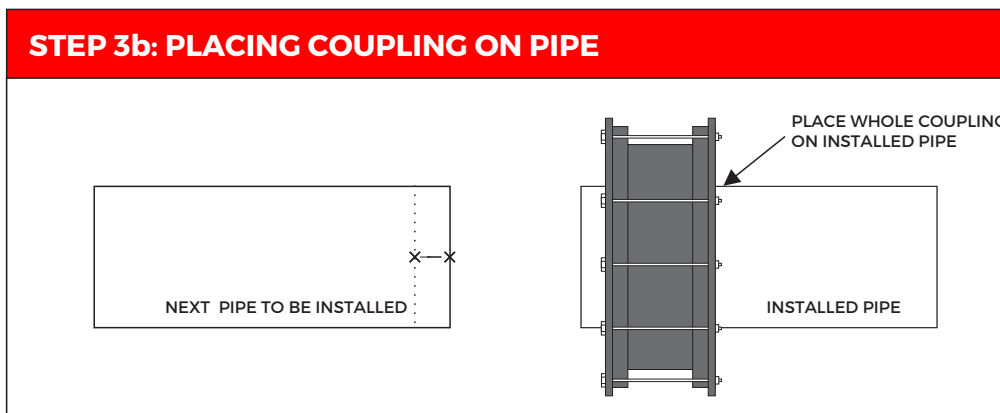

c) Adjust setting gap between pipe ends as necessary according to the following table:

Setting Gap	Min (mm)	Max (mm)
Up to DN200	16	32
Over DN250 to DN700	20	40

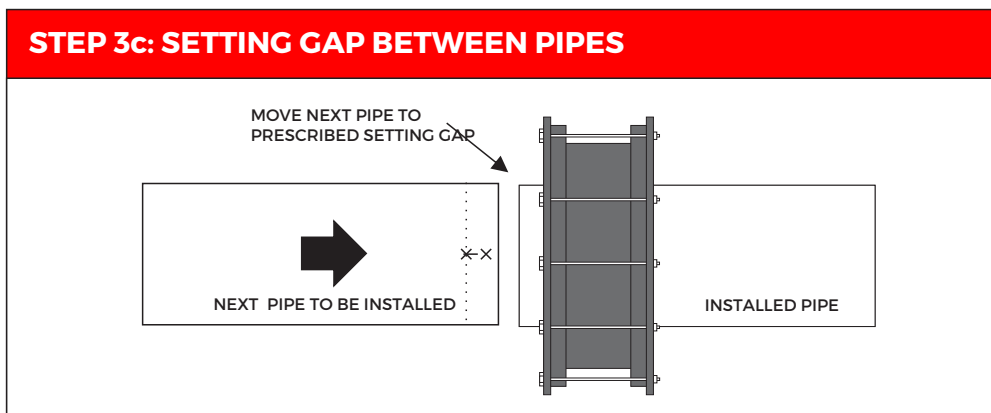

d) Using marks made on the pipes, move the coupling until the outside edge of the end rings line up with the mark made on the pipes.

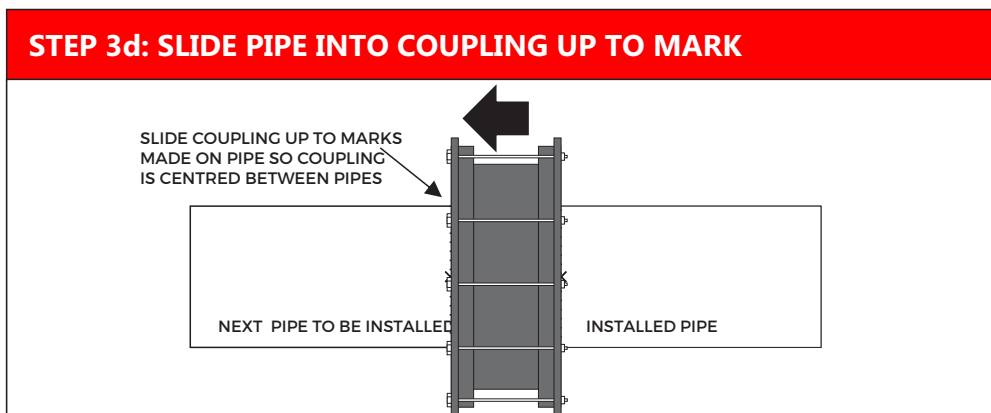

STEP 4: TIGHTENING FASTENERS

Lightly apply mineral based oil to bolt threads to facilitate installation. To assure correct rubber seal compression, bolts must be tightened in diametrically opposite pairs as per the drawings below, similar to the way a motor vehicle wheel is tightened. Bolt up evenly giving the nuts 2 or 3 turns at a time to the prescribed torque rating as follows:

M12 Bolts: Torque = 70 - 80Nm

The bolts must be thoroughly tightened to the prescribed torque rating given above, working around the coupling as many times as necessary. On completion, the radial gap between pipe and coupling should be even all the way round. Rubber may be seen to extrude into the gap.

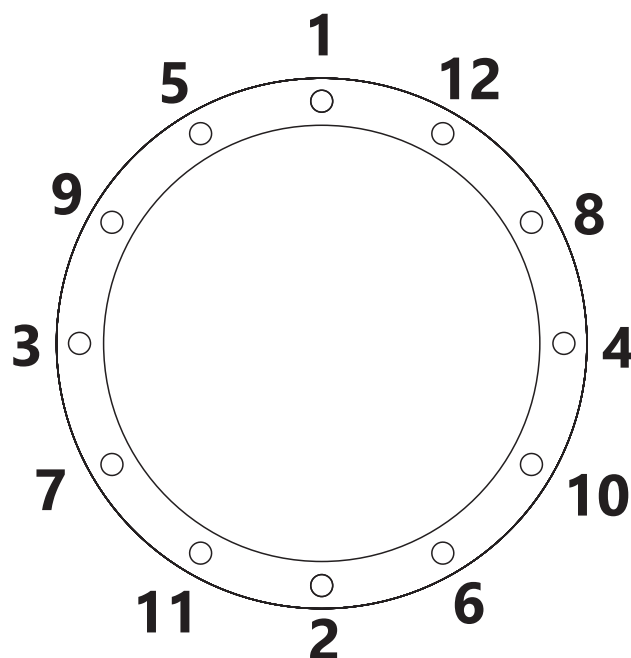

STEP 5: TESTING

If any leakages are detected on the couplings when the pipeline is being tested, the fasteners on the affected coupling needs to be tightened further until no further leakage occurs.

OPERATION AND MAINTENANCE

There are no specific maintenance or special operational requirements for these couplings. It may however be necessary to re-tighten the fasteners on these couplings from time to time due to the vibrations experienced during the operation of a pipeline which may cause the fasteners and accordingly the gaskets to relax.

There is no prescribed time period for this type of maintenance and the operator has to determine whether re-tightening may be needed based on visual inspections. This should typically be evident from some leakage being witnessed on the couplings.

STORAGE

Couplings should be stored in a cool dark place at below 65 degrees Celsius. Ensure the couplings are stored away from direct sunlight any electrical discharges. Gaskets should always be stored in an unstressed condition, and may never hang, even for a short time

TROUBLESHOOTING

If any problems are experienced, troubleshooting should be approached in a methodical fashion.

1. Is the coupling the correct one for the application? If it is not, replace with correct coupling.
2. Was there any pipe movement? If so, strap or restrain the pipes and reinstall the coupling.
3. Was there any angular deflection? If so, strap or restrain the pipes and reinstall the coupling.
4. Was the gasket uniformly compressed and end ring evenly tightened? If it wasn't, loosen and retighten the bolts as specified in these installation instructions. The coupling might have to be strapped or restrained to prevent excessive movement which could also dislodge the gasket.
5. Was the correct bolt torque used? If it wasn't, re-tighten and torque the bolts to the prescribed installation specifications. The pipeline must be depressurised prior to re-tightening.
6. Were the couplings properly aligned? If it wasn't, loosen the bolts, align and re-tighten them according to these installation instructions.
7. Is the pipe oval or out of specification? Check this by measuring the pipe OD at open end in at least four positions.
8. Was the rubber gasket properly installed? If it wasn't, replace the rubber seal and follow these installation instructions.
9. Was the setting gap correct? If it wasn't, reinstall the coupling using correct setting gaps.
10. Was lubrication used on the rubber gasket as prescribed? If it wasn't, strip the coupling, apply lubricant to the outside of the rubber and reinstall as per these installation instructions.
11. Is the coupling ID correct? If it is incorrect, please contact supplier



CONTACT DETAILS

Sales and Distribution

South Africa
Office: + 27 12 347 5595
Fax: + 27 12 347 5592
Email: sales@pipespecials.co.za

Physical Address

2nd Floor
Fountain Square
78 Kalkoen Street
Monument Park x 2
Pretoria
South Africa

Mozambique Manufacturing Plant

Physical Address

Parque Industrial de Beluluane
Boane District
Maputo Province
Lot 32 - 48

Websites

www.pipespecials.co.za
www.capitalstarsteel.co.za